

Minicilindros Serie 16, 23, 24 y 25



- Serie 16: Ø 8, 10, 12 mm - no magnéticos
- Serie 23: Ø 16, 20, 25 mm - magnéticos autoamortiguados
- Serie 24: Ø 16, 20, 25 mm - magnéticos
- Serie 25: Ø 16, 20, 25 mm - magnéticos amortiguados



- » Simple y doble efecto
- » Según norma ISO 6432
- » Vástago y camisa en inox
- » Cabezales en aluminio anodizado
- » Tipos de amortiguación: mecánico con parachoques, amortiguación neumática automática, amortiguación neumática ajustable

Los minicilindros de las Series 16, 23, 24 y 25 están diseñados según ISO 6432. Es posible elegir entre tres tipos diferentes de amortiguación: mecánica elástica en las Series 16 y 24), amortiguación neumática ajustable (Serie 25) y amortiguación neumática automática (Serie 23). Esta última versión, gracias a un sistema patentado, ajusta automáticamente la amortiguación para proporcionar una desaceleración óptima durante toda la fase de amortiguación. El cilindro goza de un movimiento suave y sin sacudidas, reduciendo las vibraciones y el ruido, a la vez que garantiza una alta fiabilidad y un rendimiento constante en el tiempo.

Las soluciones técnicas utilizadas y la elección adecuada de los materiales nos han permitido disponer de una serie completa de minicilindros, versátil y muy fiable. Son adecuados para ser utilizados en una multitud de aplicaciones industriales, especialmente cuando las condiciones de funcionamiento experimentan cambios en el tiempo como, por ejemplo, el desgaste de los componentes de la máquina. Los accesorios de montaje de estos cilindros permiten su utilización en distintas situaciones de amarre.

GENERAL DATA

Tipo de construcción	Rebordeado
Funcionamiento	Simple y doble efecto
Diseño	ISO 6432
Materiales	Cabezales Al anodizado - vástago y camisa inox - pistón Al - juntas NBR/PU - otros: ver codificación
Sujección	Punta de vástago - brida - escuadras - basculante
Carreras mín - máx	Serie 16 Ø 8 ÷ Ø 10: 10 - 250 mm - Serie 16: Ø 12: 10 - 300 mm - Serie 23, 24 y 25 Ø 16: 10 - 600 mm; Ø 20 - Ø 25: 10 - 1000 mm
Diámetro	Serie 16: Ø 8, 10, 12 - Serie 23, 24 y 25: Ø 16, 20, 25
Temperatura de trabajo	0°C ÷ 80°C (con aire seco -20°C)
Presión de trabajo	1 ÷ 10 bar (doble efecto); 2 ÷ 10 bar (simple efecto)
Fluido	Aire filtrado, clase 7.8.4 según norma ISO 8573-1. En caso de utilizar aire lubricado, se aconseja aceite ISO VG32 y no interrumpir nunca la lubricación.
Velocidad	10 ÷ 1000 mm/seg (sin carga)

TABLA DE CARRERAS ESTÁNDAR PARA MINICILINDROS

■ = Doble efecto
 ✕ = Simple efecto

CARRERAS ESTÁNDAR															
Serie	Ø	10	25	40	50	80	100	125	160	200	250	300	320	400	500
16	8	■✕	■✕	■✕	■✕	■	■	■	■	■					
16	10	■✕	■✕	■✕	■✕	■	■	■	■	■					
16	12	■✕	■✕	■✕	■✕	■	■	■	■	■					
24	16	■✕	■✕	■✕	■✕	■	■	■	■	■	■	■	■	■	■
24	20	■✕	■✕	■✕	■✕	■	■	■	■	■	■	■	■	■	■
24	25	■✕	■✕	■✕	■✕	■	■	■	■	■	■	■	■	■	■
23/25	16	■	■	■	■	■	■	■	■	■	■	■	■	■	■
23/25	20	■	■	■	■	■	■	■	■	■	■	■	■	■	■
23/25	25	■	■	■	■	■	■	■	■	■	■	■	■	■	■

EJEMPLO DE CODIFICACIÓN

24	N	2	A	16	A	100	
-----------	----------	----------	----------	-----------	----------	------------	--

24	SERIE 16 = no magnético, amortiguación mecánica 23 = magnético, autoamortiguado 24 = magnético, amortiguación mecánica 25 = magnético, amortiguación regulable	
N	VERSIÓN N = estándar	
2	FUNCIONAMIENTO 1 = simple efecto, resorte frontal, no amortiguado (Series 16, 24) 2 = doble efecto 3 = doble efecto, vástago pasante 7 = simple efecto, vástago pasante (Series 16, 24)	SÍMBOLOS NEUMÁTICOS CS02 (s. 16) - CS06 (s. 24) CD01 (s. 16) - CD08 (s. 24) - CD23 (s. 23) - CD09 (s. 25) CD05 (s. 16) - CD12 (s. 24) - CD24 (s. 23) - CD13 (s. 25) CS04 (s. 16) - CS10 (s. 24)
A	MATERIALES A = vástago inox AISI 303 rolado - camisa inox AISI 304 - cabezales AL anodizado	
16	DIÁMETRO 08 = 8 mm (Serie 16) 10 = 10 mm (Serie 16) 12 = 12 mm (Serie 16) 16 = 16 mm (Serie 23, 24 y 25) 20 = 20 mm (Serie 23, 24 y 25) 25 = 25 mm (Serie 23, 24 y 25)	
A	TIPO CONSTRUCTIVO A = tuerca cabezal V + tuerca vástago U RL = cilindro con bloqueo vástago Ø20 - Ø25	
100	CARRERA (ver tabla)	
	= estándar V = juntas vástago en FKM W = todas las juntas en FKM, +130°C (solo para Serie 25) (_ _) = vástago extendido _ _ mm	

SÍMBOLOS NEUMÁTICOS

Abajo están ilustrados los símbolos neumáticos indicados en el EJEMPLO DE CODIFICACIÓN.

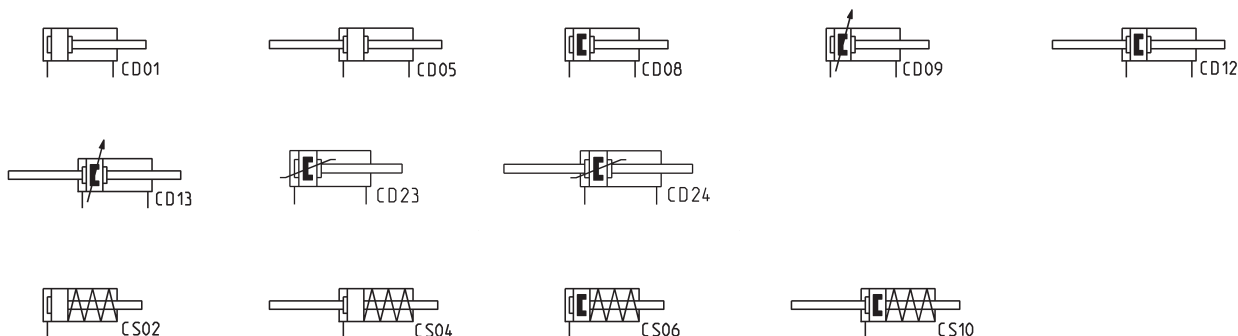

ACCESORIOS PARA MINICILINDROS SERIE 16 - 23 - 24 - 25



Amarre con patas Mod. B



Amarre de brida Mod. E



Basculante Mod. I



Horquilla Mod. G



Articulación esférica Mod. GA



Horquilla articulada Mod. GY



Tuerca vástago Mod. U



Tuerca vástago Mod. V



Accesorio autoalineable Mod. GK



Conjunto compensador Mod. GKF

MINICILINDROS SERIE 16, 23, 24 Y 25

Todos los accesorios se suministran separados del cilindro, excepto la tuerca vástago Mod. U y la tuerca cabezal Mod. V.

SERIE 23: MASA APLICABLE SEGÚN LA VELOCIDAD DEL CILINDRO

ELECCIÓN DEL CILINDRO

- 1) Elegir el tamaño adecuado según la fuerza necesaria durante el funcionamiento
- 2) Comprobar en el gráfico si las condiciones de trabajo (masa y velocidad) se intersectan en un punto por debajo de la curva que corresponda al tamaño elegido

m = masa aplicada al cilindro
v = velocidad aplicada al cilindro (m/s)

Ejemplo:
Diámetro = 20 mm; Velocidad máxima = 0,4 m/s; Masa aplicable = 6kg;

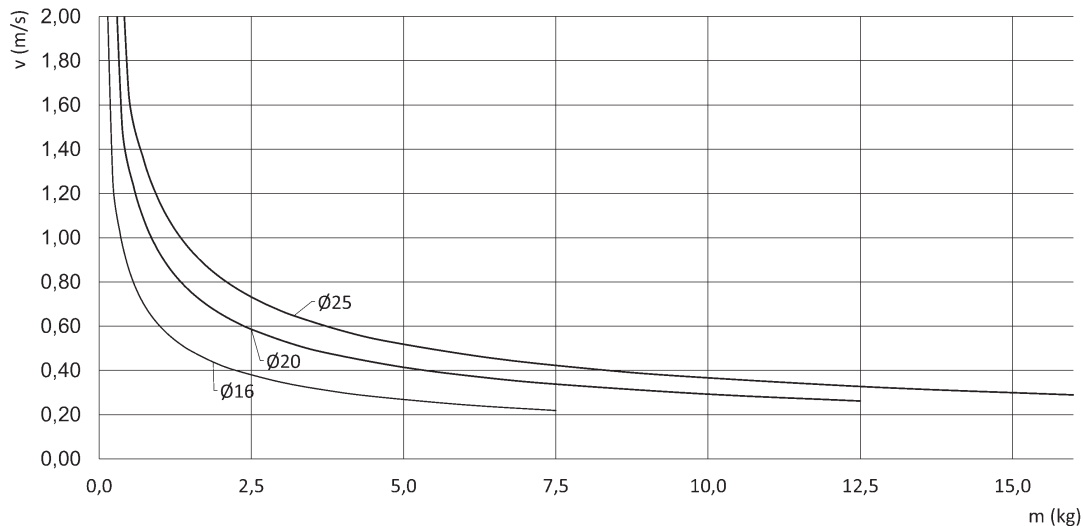

Minicilindros Serie 16 -23 -24 -25



+ = sumar la carrera

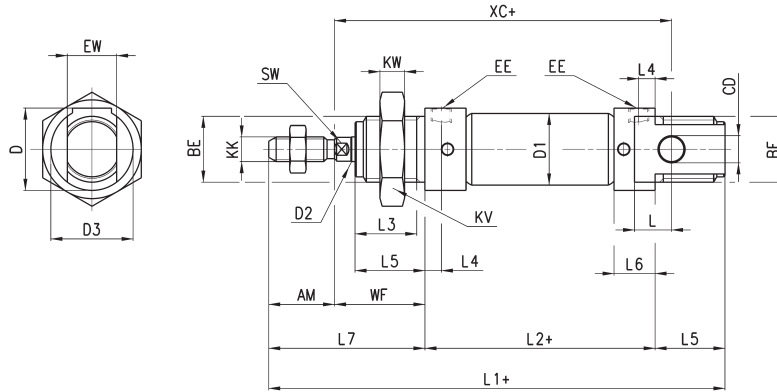

DIMENSIONES																									
Serie	∅	EW	KW	BE	KK	CD	\varnothing D1	EE	\varnothing D2	L1+	XC+	L2+	AM	L3	L4	L5	L	WF	L6	L7	KV	SW	D	D3	Carrera de amortiguación delantera/trasera
16	8	8	7	M12x1,25	M4x0,7	4	9,3	M5	4	86	64	46	12	10	4,5	12	6	16	9	28	19	-	15	15	-
16	10	8	7	M12x1,25	M4x0,7	4	11,3	M5	4	86	64	46	12	10	4,5	12	6	16	9	28	19	-	15	15	-
16	12	12	8	M16x1,5	M6x1	6	13,3	M5	6	105	75	50	16	15	4,5	17	9	22	9	38	24	5	20,5	20	-
23	16	12	8	M16x1,5	M6x1	6	17,3	M5	6	111	82	56	16	15	5,5	17	9	22	12	38	24	5	20,5	20	10
24-25	16	12	8	M16x1,5	M6x1	6	17,3	M5	6	111	82	56	16	15	5,5	17	9	22	10	38	24	5	20,5	20	10
23-24-25	20	16	10	M22x1,5	M8x1,25	8	21,3	G1/8	8	132	95	68	20	18	8	20	12	24	16	44	32	7	27	27	15
23-24-25	25	16	10	M22x1,5	M10x1,25	8	26,5	G1/8	10	141,5	104	69,5	22	20	8	22	12	28	16	50	32	9	27	27	16

Minicilindros Serie 16 - 23 - 24 - 25 - vástago pasante



+ = sumar la carrera
++ = sumar la carrera 2 veces

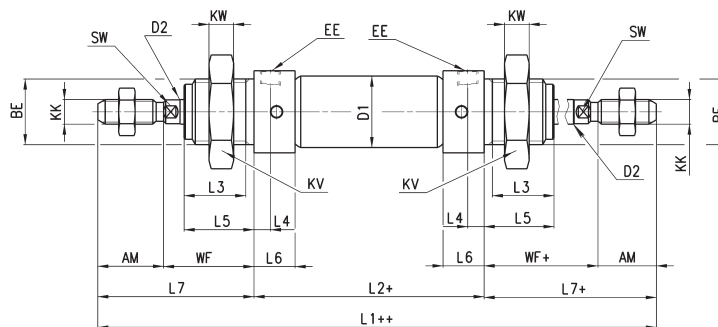

DIMENSIONES																						
Serie	∅	KW	BE	KK	\varnothing D1	EE	\varnothing D2	L1++	L2+	AM	L3	L4	L5	WF+	L6	L7+	KV	SW	Carrera de amortiguación delantera/trasera			
16	8	7	M12x1,25	M4x0,7	9,3	M5	4	102	46	12	10	4,5	12	16	9	28	19	-	-			
16	10	7	M12x1,25	M4x0,7	11,3	M5	4	102	46	12	10	4,5	12	16	9	28	19	-	-			
16	12	8	M16x1,5	M6x1	13,3	M5	6	126	50	16	15	4,5	17	22	9	38	24	5	-			
23	16	8	M16x1,5	M6x1	17,3	M5	6	132	56	16	15	5,5	17	22	12	38	24	5	10			
24-25	16	8	M16x1,5	M6x1	17,3	M5	6	132	56	16	15	5,5	17	22	10	38	24	5	10			
23-24-25	20	10	M22x1,5	M8x1,25	21,3	G1/8	8	156	68	20	18	8	20	24	16	44	32	7	15			
23-24-25	25	10	M22x1,5	M10x1,25	26,5	G1/8	10	169,5	69,5	22	20	8	22	28	16	50	32	9	16			

Minicilindros Serie 23 - 24 - 25 - con bloqueo de vástago Mod. RLC



+ = sumar la carrera

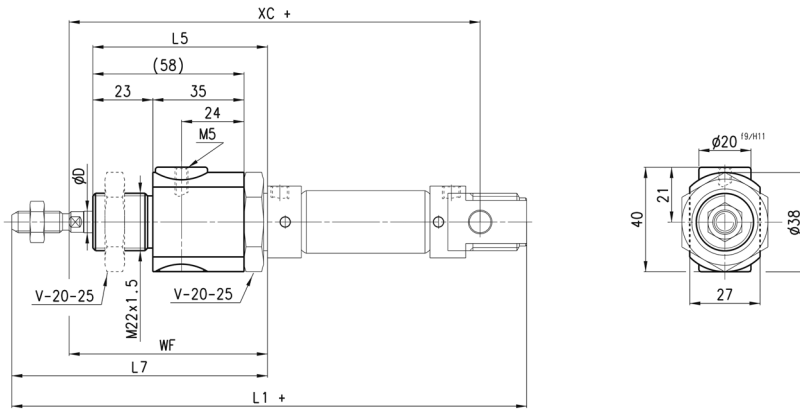

DIMENSIONES								
Serie	∅	⁶⁷ D	WF	L5	L7	XC+	L1+	F (N)
23-24-25	20	8	74	70	94	145	182	300
23-24-25	25	10	76	70	98	152	189,5	400

MINICILINDROS SERIE 16, 23, 24 Y 25

Amarre con patas Mod. B

Material: acero zincado.



El suministro incluye:
2 Patas
1 Tuerca Mod. V

+ = sumar la carrera

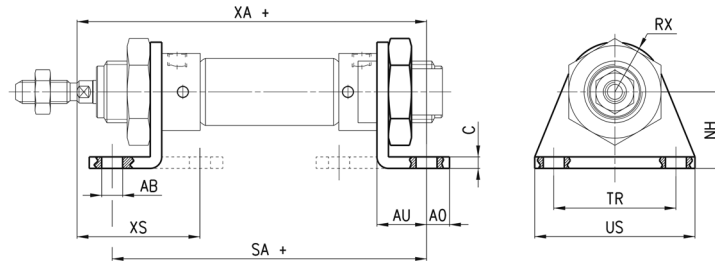

DIMENSIONES												
Mod.	∅	∅AB	XS	XA+	SA+	AO	AU	C	RX	TR	US	NH
B-8-10	8-10	4,5	24	72,5	67	4,5	10,5	2,5	10	25	35	16
B-12-16	12	5,5	32	82,5	76	6	13	3	13	32	42	20
B-12-16	16	5,5	32	91	82	6	13	3	13	32	42	20
B-20-25	20	6,6	36	108	100	8	16	4	20	40	54	25
B-20-25	25	6,6	40	113,5	101,5	8	16	4	20	40	54	25

Amarre de brida Mod. E

Material: acero zincado.



+ = sumar la carrera

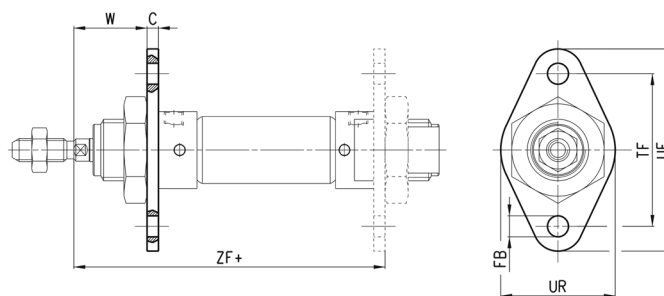

DIMENSIONES								
Mod.	∅	W	C	ZF+	FB	UF	TF	UR
E-8-10	8-10	13,5	2,5	64,5	4,5	40	30	25
E-12-16	12	19	3	75	5,5	53	40	30
E-12-16	16	19	3	81	5,5	53	40	30
E-20-25	20	20	4	96	6,6	66	50	40
E-20-25	25	24	4	101,5	6,6	66	50	40

Basculante Trasero Mod. I



El suministro incluye:
1x basculante hembra en acero
zincado
1x perno en acero inox
2x Seeger en acero

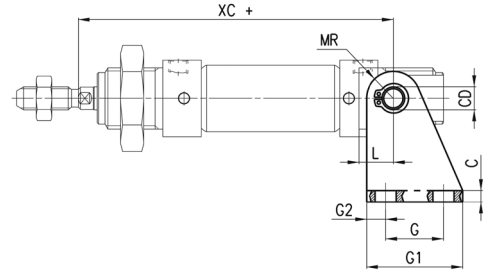
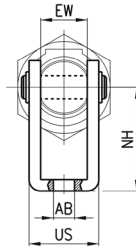

+ = sumar la carrera

DIMENSIONES													
Mod.	∅	EW	∅AB	US	NH	XC+	MR	L	G2	G	G1	CD	C
I-8-10	8-10	8	4,5	13,1	24	64	5	6	3,5	12,5	20	4	2,5
I-12-16	12	12	5,5	18,1	27	75	7	9	5	15	25	6	3
I-12-16	16	12	5,5	18,1	27	82	7	9	5	15	25	6	3
I-20-25	20	16	6,6	24,1	30	95	10	12	6	20	32	8	4
I-20-25	25	16	6,6	24,1	30	104	10	12	6	20	32	8	4

Horquilla Mod. G

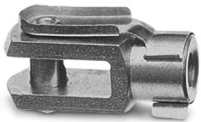

ISO 8140
Material: acero zincado.

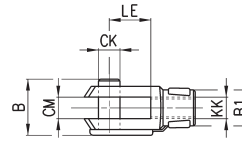
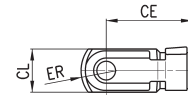

DIMENSIONES										
Mod.	∅	CL	ER	CE	B	CM	∅CK	LE	KK	∅B1
G-8-10	8-10	8	5	16	11	4	4	8	M4x0,7	8
G-12-16	12-16	12	7	24	16	6	6	12	M6x1	10
G-20	20	16	10	32	22	8	8	16	M8x1,25	14
G-25-32	25	20	12	40	26	10	10	20	M10x1,25	18

Rótula para vástago Mod. GA



ISO 8139
Material: acero zincado.

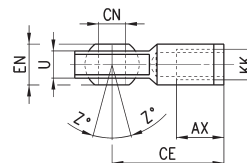
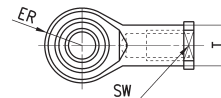

DIMENSIONES											
Mod.	∅	∅CN ^(H7)	U	EN	ER	AX	CE	KK	∅T	Z	SW
GA-8-10	8-10	5	6	8	9	10	27	M4x0.7	9	6.5°	9
GA-12-16	12-16	6	7	9	10	12	30	M6X1	10	6.5°	11
GA-20	20	8	9	12	12	16	36	M8X1.25	12.5	6.5°	14
GA-32	25	10	10.5	14	14	20	43	M10X1.25	15	6.5°	17

Horquilla articulada Mod. GY



ISO 8139
Material: zamak y acero zincado.

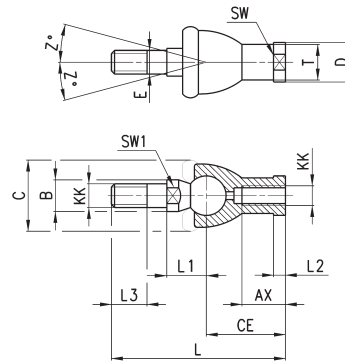

DIMENSIONES																	
Mod.	∅	Z	E	SW	\varnothing_T	\varnothing_D	\varnothing_C	\varnothing_B	KK	L3	SW1	L1	L	CE	AX	L2	
GY-12-16	12-16	15	6	11	10	13	20	10	M6X1	11	8	12,2	55	28	15	5	
GY-20	20	15	8	14	12,5	16	24	12	M8X1,25	12	10	16	65	32	16	5	
GY-32	25	15	10	17	15	19	28	14	M10X1,25	15	11	19,5	74	35	18	6,5	

Tuerca vástago Mod. U



ISO 4035
Material: acero zincado.

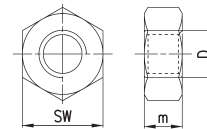

DIMENSIONES				
Mod.	∅	SW	m	D
U-8-10	8-10	7	3	M4X0,7
U-12-16	12-16	10	4	M6X1
U-20	20	13	5	M8X1,25
U-25-32	25	17	6	M10X1,25

Tuerca cabezal Mod.V



ISO 4035
V-8-10 / V-20-25 no estándar.
Material: acero zincado.

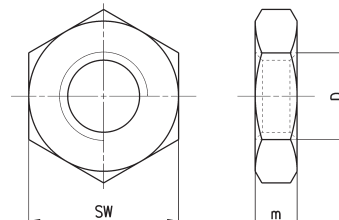

DIMENSIONES				
Mod.	∅	D	m	SW
V-8-10	8-10	M12X1,25	7	19
V-12-16	12-16	M16X1,5	8	24
V-20-25	20-25	M22X1,5	10	32

Articulación autoalineante Mod. GK

Material: acero zincado.

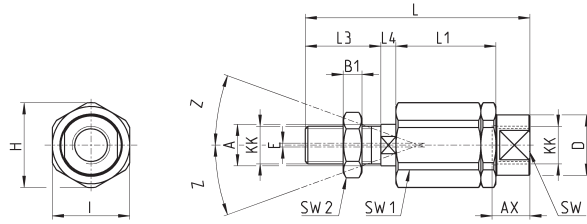

DIMENSIONES

Mod.	∅	H	I	Z	₆ A	KK	E	L	L3	L4	L1	B1	SW2	SW1	AX	SW	₆ D
GK-12-16	12-16	14.5	13	3	6	M6x1	1	35	11	2.5	17.5	4	10	5	12.5	7	8.5
GK-20	20	19	17	4	8	M8x1,25	2	57	21	5	26	4	13	7	16	11	12.5
GK-25-32	25-32	32	30	4	14	M10x1,25	2	71.5	20	7.5	35	5	17	12	22	19	22

Placa Compensadora Mod. GKF

Material: acero zincado.

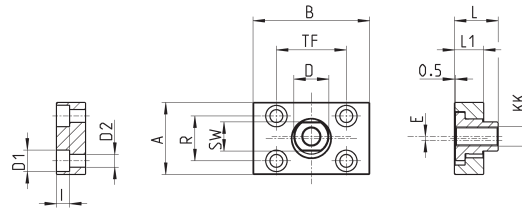

DIMENSIONES

Mod.	∅	∅ D1	I	∅ D2	A	R	SW	B	TF	∅ D	E	L	L1	KK
GKF-20	20	5,5	-	-	30	20	13	35	25	14	1,5	22,5	10	M8x1,25
GKF-25-32	25	11	6,8	6,6	37	23	15	60	36	18	2	22,5	15	M10x1,25